

| <br><br>Adr.: Statnett SF<br>Nydalen allé 33<br>PB 4904 Nydalen<br>0423 Oslo  | <b>Technical specification</b>   |               |        |                 |          |
|--|--|---------------|--------|-----------------|----------|
|  | Tittel / Title<br><br><b>Modelling requirements for PSS/E<br/>wind farm models</b> |               |        |                 |          |
| Classification   | Responsible  |               |        | Number of pages |          |
| Ansvarlig / Responsible  | Dokument nr. / Document no.  |               |        |                 |          |
| <p>This instruction describes the requirements for PSS/E simulation models to be delivered to Statnett as a part of the grid code compliance monitoring process and grid data reporting (Fosweb data). Delivery of a compliant model is an important precondition for demonstrating grid code compliance. It is also part of the mandatory documentation required to receive final approval for the power system data reporting according to Norwegian law. By following this instruction, the overall quality and compatibility of the models can be ensured.</p> <p>The modelling requirements are applicable as such for all new build projects. For retrofit projects - such as partial renewal or modification of an existing system - the exact scope of modelling shall be agreed separately.</p> <p>It is highly recommended to use the latest version of this instruction as a reference for modelling requirements for a specific project at the time of the modelling studies. As per request at the time when the connection process is concluded, Statnett will confirm the version of the modelling instruction to be used for a specific project.</p> |  |               |        |                 |          |
| Most current version of this document can be found at:   |  |               |        |                 |          |
|  |  |               |        |                 |          |
| Distribusjon / Distribution  |  |               |        |                 |          |
| Rev.   | Date   | Description   | Author | Checked         | Approved |
| 1  | 13.11.2023   | First version | JÅW    | SS              | ASRR     |

**INNHold / TABLE OF CONTENTS**

|           |  |          |
|-----------|--|----------|
| <b>1.</b> | <b>CONFIDENTIALITY</b> .....                                   | <b>3</b> |
| <b>2.</b> | <b>GENERAL REQUIREMENTS</b> .....                              | <b>3</b> |
| 2.1       | STRUCTURE AND AGGREGATION.....                                 | 3        |
| 2.2       | FUNCTIONALITIES .....  | 4        |
| 2.3       | USABILITY .....  | 4        |
| 2.4       | MODEL DOCUMENTATION .....                                      | 4        |
| <b>3.</b> | <b>SIMULATION PROGRAM SPECIFIC REQUIREMENTS FOR PSSE</b> ..... | <b>5</b> |
| 3.1       | POWERFLOW MODEL .....  | 5        |
| 3.2       | DYNAMIC MODEL .....  | 6        |
| 3.2.1     | <i>Type requirements</i> .....                                 | 6        |
| 3.2.2     | <i>Version requirements</i> .....                              | 6        |
| 3.2.3     | <i>Functional requirements</i> .....                           | 6        |
| <b>4.</b> | <b>REFERENCES</b> .....  | <b>6</b> |
| 4.1       | VERSION 1 .....  | 7        |

## 1. Confidentiality

All models and related technical information given to Statnett will be treated as confidential. However, received models must be possible to share within the Nordic TSOs as this is needed for common TSO studies and models.

Generic library models of renewables (e.g. WECC models for renewables) will be used when delivering an overall Norwegian or Nordic model to other projects/third parties outside the Nordic TSOs. Project specific NDAs (non-disclosure agreement) are not issued.

## 2. General requirements

This chapter describes the general model requirements.

### 2.1 Structure and aggregation

The power plant model shall include all physical equipment that essentially affect the operation of the power plant, such as the generators, transmission lines and cables, transformers, capacitor banks etc.

If the modelled power plant includes multiple similar generating units, such as wind turbines, these should be represented as aggregated units. All generating units of the same type (identical design) should be combined into a single aggregate. The electrical network between the power plant connection point and the main transformers shall be modelled. All main transformers shall be modelled separately. The internal electrical network, including the transmission lines, cables, step-up transformers, capacitor banks, filters and loads behind each main transformer shall be modelled as aggregated components.

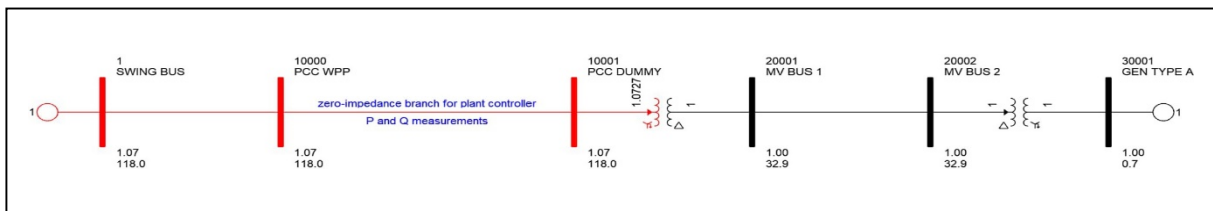

Figure 2: Example topology of an aggregated model with one main transformer

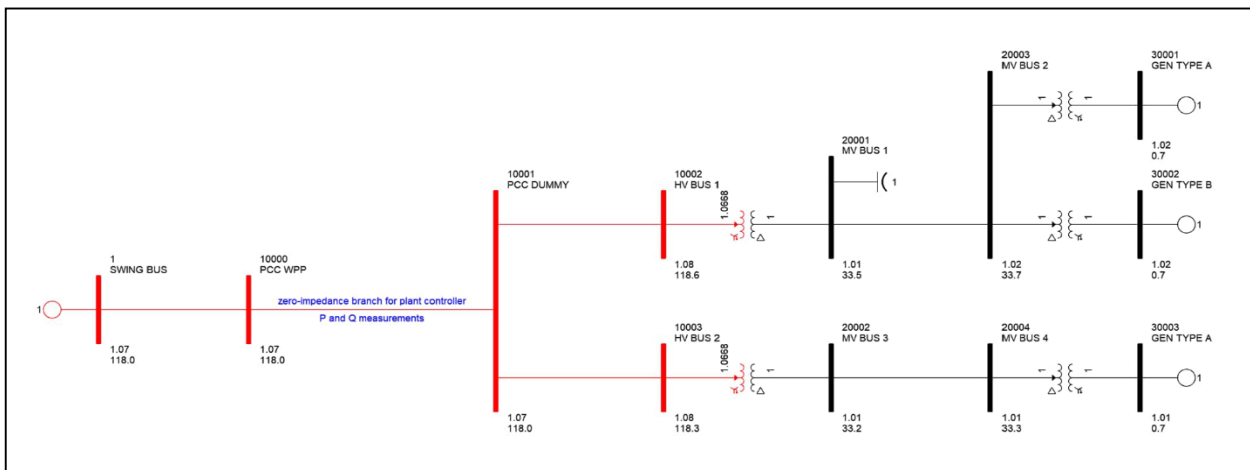

Figure 1: Example topology of an aggregated model with two main transformers and two types of generators

Example topologies for power plants with one and two main transformers are presented in Figure 1 and Figure 2. This topology principle shall be used in the lumped simulation models. Dummy bus and zero-impedance branch shall be included only if required by plant controller.

## 2.2 Functionalities

The model operating range shall reflect the actual power plant operating range, and the model shall include all limiters that restrict the operation of the power plant. The limiters shall represent the actual power plant response.

The model shall have the capability to change the control mode to any control mode possible in the actual power plant, such as voltage droop control, reactive power control and power factor control. The setpoints of these control modes, such as active power, reactive power, and voltage setpoints shall also be changeable during the simulation. The modification of the essential control parameters (e.g. voltage regulator settings, fault current infeed, power ramp rates) must be available for the user.

The model shall include all generator protection functionalities relevant from the power system perspective. Protection settings used in the final model shall correspond to the ones to be used on site. The model shall announce the type of protection in case of tripping.

Protection functions shall be modelled within the limits of simulation program functionalities.

## 2.3 Usability

The project specific model is expected to be fully compatible and operable as part of large system models. To ensure this, the external dependencies such as library files etc. shall either have unique version numbering, or there should be a capability to rename the dependencies. If the model does not operate in large system models, the issues must be identified and resolved together with Statnett. The number of model dependencies are recommended to be kept at a minimum.

Any unstable operation of the model shall not result in crashing of the simulation, and any mechanism (protection etc.) that ceases the unstable operation shall reflect the actual power plant response.

The model shall not require use of specific operating system settings, such as specific decimal separator.

User specific models are not allowed to use fixed internal model addressing in PSSE, the model must be able to run in different study cases without the need for manual changes of model addresses.

## 2.4 Model documentation

The model documentation shall include:

- Version history of the complete plant model. If any changes to the model are required after the initial delivery, these changes shall be listed in the version history.
- Compatibility, including which PSS/E versions the model supports.
- Requirements for the simulation environment. This includes the minimum and maximum simulation time steps and other relevant parameters.
- List of library files or DLLs in PSS/E. The list of all needed files that are required to run the model shall be documented.
- Limitations of the project specific model performance. Defined as the model response matching actual power plant performance. This shall include:
  - o minimum SCR at turbine level and point of common coupling
  - o model bandwidth and observable oscillation frequencies.
- Description of protection functions and tripping signals. This includes the description of what protection signals are available to the user, and how to view these signals.
- Description of the modelled additional functionalities such as power oscillation damping, subsynchronous damping circuit and control logic of mechanically switched capacitor banks.
- Transfer functions and bode diagram of the possible power system stabilizer and/or power oscillation damping functionality.

The following model usage instructions:

- How to change the control mode and the setpoints of each available control mode.
- How to parametrize the dynamic model in case of bus number changes
- A full list of ICONs, CONs, STATEs and VARs with descriptions.

### 3. Simulation program specific requirements for PSSE

#### 3.1 Powerflow model

The base MVA of the power flow case shall be 1000 MVA. The base voltage for the buses must be set as defined in Table 1. Note that the base voltages defined in Table 1 are only for modelling purposes and e.g. reference value for voltage control is based on local conditions and relevant grid code requirements.

|            | Base voltage for buses |
|------------|------------------------|
| 395–420 kV | 400 kV                 |
| 300-275 kV | 300 kV                 |
| 215–245 kV | 220 kV                 |
| 140-123 kV | 130 kV                 |
| 105–123 kV | 110 kV                 |
| 70-60 kV   | 66 kV                  |
| 45-55kV    | 50kV                   |
| <45 kV     | $U_n$                  |

TABLE 1. SELECTING THE BASE VOLTAGE OF THE BUSES

The generator shall have  $Q_{\min}$  and  $Q_{\max}$  set as the limits during  $P=\max$  and  $U_{LV}=1.0$  pu operation. Possible compensation devices must be modelled separately. In case the dynamic model measures power flow from the power plant, a dummy bus can be included before the point of common coupling. There shall not be any measurements over the branch representing the background network i.e. from swing bus to study network.

Bus numbering can be selected freely in the range 100-8999.

The model shall include sequence data. The short circuit contribution from the plant at POC (stationary, transient, subtransient) shall be correct and reproducible by the model, both for symmetrical and unsymmetrical grid faults.

## 3.2 *Dynamic model*

### 3.2.1 Type requirements

Dynamic models which include calls into CONEC and CONET subroutines are not allowed. Only table-driven models shall be used.

In addition to project specific custom models, parameters for generic library models of PSS/E 36 or higher should be delivered (e.g. WECC models for renewables). It is known that generic library models cannot be parametrized to exactly match the response of a custom model in all areas. Generic library models for inverter-based resources should be parametrized to prioritize the following (given in the order of precedence):

- Voltage control performance
- Fault current contribution
- Active and reactive power fault recovery

### 3.2.2 Version requirements

The model shall be compatible with PSS/E 36 or higher. In case dynamic model source code is delivered it must be developed in FORTRAN 90 or higher.

To ensure traceability, version and sub-version numbering shall be included in the dynamic model's name.

### 3.2.3 Functional requirements

For the dynamic models the following requirements must be fulfilled:

- Models shall be able to run multiple disturbances in the same simulation
- Model flat-run simulation shall not present any changes from steady state
- Models shall have stable operation for simulation times up to 5 minutes.
- The initialization of the model shall not cause initial condition suspects.
- The models shall be able to work with time step from 1 to 10 ms. Accuracy of the model based on the time step shall be described.

Linearized models that are accurate only for a single operating point are not acceptable. In case power plant includes compensation devices, inclusion of the switching logic in the model is preferred.

## 4. References

- [1] "Forskrift om produksjon, omforming, overføring, omsetning, fordeling og bruk av energi m.m. (energilovforskriften)", Lovdata, <https://lovdata.no/dokument/SF/forskrift/1990-12-07-959>
- [2] "System operation Guidelines", ENTSO-E, [https://www.entsoe.eu/network\\_codes/sys-ops/](https://www.entsoe.eu/network_codes/sys-ops/)
- [3] "Modelling instruction for PSS/E and PSCAD models", Fingrid 2022-05-05, <https://www.fingrid.fi/globalassets/dokumentit/fi/palvelut/kulutuksen-ja-tuotannon-liittaminen-kantaverkkoon/modelling-instruction-for-psse-and-pscad-models.pdf>

#### **4.1 Version 1**

- As far as applicable based on and coordinated with Fingrid's spec for PSS/E models [3]